

# GHSA 750-006 Series

## Spring-Loaded AC-LVDT Position Sensors



### Description

The Macro Sensors GHSA 750 Series of 19.0 mm diameter spring-loaded AC-LVDTs are designed for a wide range of position measurement and dimensional gaging applications. These rugged hermetically sealed sensors are constructed entirely of stainless steel and intended for general industrial use. The coil windings are sealed against hostile environments to IEC standard IP-68. Electrical termination is through a sealed axial connector; the mating connector plug is supplied with a unit.

The sensor consists of a spring loaded shaft running in a precision sleeve bearing and connected to the core of an LVDT. The use of a precision sleeve bearing results in measurement repeatability of  $0.6 \mu\text{m}$  or better. The output from the LVDT can be connected to any standard LVDT signal conditioner and then passed to a gaging column display, digital readout, or computer based data acquisition system.

The probe shaft is fully extended by a spring exerting a nominal force of 170 to 570 grams depending upon total range. The contact tip supplied is an AGD standard number 9 made

### Features

- Ranges of  $\pm 1 \text{ mm}$  to  $\pm 50 \text{ mm}$
- In-line connector, mating plug included
- Repeatability of  $0.6 \mu\text{m}$
- Non-linearity less than  $\pm 0.25\%$  of FRO
- Coil environmentally sealed to IEC IP-68

### Applications

- Industrial gaging systems
- Electronic dial indicators
- Fabricated metal products gaging
- Materials testing apparatus
- Large shaft TIR measurements

from chrome plated hardened tool steel. It is fully interchangeable with other AGD contact tips.

Available in ranges of  $\pm 1 \text{ mm}$  to  $\pm 50 \text{ mm}$ , the maximum linearity error for a GHSA 750 Series sensor is  $\pm 0.25\%$  of full range output using a statistically best-fit straight line derived by the least squares method.

For simplified mounting the GHSA 750 has a 1/2-20 UNF 2A thread on the front of the housing, permitting the user to install the LVDT in a mating threaded part or by using the two hex nuts furnished with the sensor. This results in a ready-to-use package for position measurements and longer range gaging applications.

All GHSA 750 Series LVDTs will operate properly with any conventional differential input LVDT signal conditioners, but operation with ratiometric LVDT signal conditioning is not recommended. Macro Sensors offers a full line of LVDT signal conditioners that will deliver optimum performance from any GHSA 750 Series LVDT.

**General Specifications**

- Input Voltage:** 3.0 V<sub>rms</sub> (nominal)
- Input Frequency:** 2.5 to 3.0 kHz
- Linearity Error:** <math>\pm 0.25\%</math> of FRO
- Repeatability Error:** <math>< 0.6 \mu\text{m}</math>
- Operating Temperature:** -55°C to +105°C
- Thermal Coefficient of Sensitivity:** -0.02%/°C (nominal)

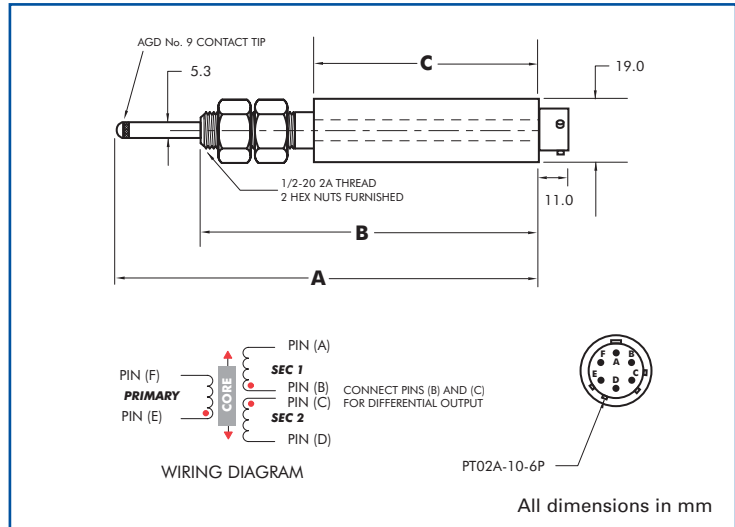

**Specifications**

Model ▶	GHSA 750 -050	GHSA 750 -125	GHSA 750 -250	GHSA 750 -500	GHSA 750 -1000	GHSA 750 -2000
Parameter ▼						
Nominal Range (mm)	±1	±3	±6	±12.5	±25	±50
Sensitivity (mV/V/mm)	240	153	98	26	24	14
Primary Impedance (Ω)	325	735	1400	1200	1250	2150
Pretravel (mm)	3.0	3.3	2.5	2.5	1.3	0.5
Overtravel (mm)	3.0	3.3	2.5	2.5	1.3	0.5
Dimension "A" (mm)	117	134	153	268	322	531
Dimension "B" (mm)	89	105	125	230	267	415
Dimension "C" (mm)	50	66	85	149	186	276
Weight (g)	82	96	113	170	179	290

**Ordering Information**

Order by model number with range  
 For accessories and compatible signal conditioners, please visit our website at [www.macrosensors.com](http://www.macrosensors.com).



*Innovators in Position Sensing*

All specifications subject to change without notice.  
 © 2007 Macro Sensors 07/02/07

7300 US Route 130 North, Bldg. 22  
 Pennsauken, NJ 08110-1541 USA  
 tel: 856-662-8000  
 fax: 856-317-1005  
[www.macrosensors.com](http://www.macrosensors.com)  
[lvdts@macrosensors.com](mailto:lvdts@macrosensors.com)

