

## LVC 2412

## Low Voltage DC Operated LVDT Signal Conditioner



### Description

The Macro Sensors LVC-2412 is a single channel signal conditioner that operates on 12 or 24 Volts DC power to support standard LVDT, RVDT, and VRT half-bridge sensors. Designed expressly for use in 24 Volt systems with PLCs and mini-PLCs, or in 12 Volt mobile and vehicular testing systems, it offers the user a choice of three analog outputs: 0 to  $\pm 10$  V DC, 0 to 10 V DC, or 4 to 20 mA (sourcing) in a 3- or 4-wire current loop configuration. Unlike most other low voltage DC operated LVDT signal conditioners, an LVC-2412's DC input power is fully isolated from its analog outputs. This allows it to be connected in either a 4-wire isolated I/O configuration, or in a 3-wire common ground system in which the power ground is connected to the output signal's ground. To provide maximum output flexibility, the 4-20 mA current loop output does not track the voltage output.

The LVC-2412 is packaged in a DIN-rail mounting thermoplastic case with recessed screw-clamp terminals for all connections and 20-turn front-panel-accessible span and zero adjustments. It uses a time-proven ASIC that produces a low distortion sine wave to excite the LVDT and employs a synchronous demodulator to convert the LVDT's AC output signal to more useful DC outputs proportional to core position.

### Features

- DIN-rail mountable
- Analog voltage or current loop output
- Outputs fully isolated from power
- Non-interactive adjustments
- No phase adjustment needed
- Supports all standard LVDTs and VR half-bridge sensors

### User Selectable Features

- 0 to  $\pm 10$  V, 0 to 10 V, or 4 to 20 mA output
- 1.5 or 3.0 Vrms LVDT excitation
- 3, 5, or 10 kHz excitation frequency
- Master/slave excitation synchronization

Additional circuitry regulates the ASIC's DC operating power and provides span and zero adjustability, a 2-pole low pass output filter, and the voltage-to-current conversion that drives the 4-20 mA current loop output.

Besides the externally adjustable span control, an LVC-2412 also incorporates movable coarse gain jumpers which allow it to operate over an LVDT full scale output signal range greater than 50 to 1. The external zero control permits output offset adjustment from -100% to +100% of full scale output. The span and zero controls do not interact with each other. The LVC-2412 does not require a phase adjustment control, so it can work satisfactorily with reasonably long cables between it and the LVDT.

By shifting a movable internal jumper in the LVC-2412, a user can choose 3, 5, or 10 kHz nominal excitation frequencies at a level of 3 Volts rms for driving normal LVDTs, changeable to 1.5 Volts rms for operating LVDTs with low primary impedance. For multiple channel applications, several LVC-2412 modules can be connected together in master/slave mode to synchronize their excitation oscillator frequency, thereby eliminating effects of heterodyning and spurious beat frequency signals, cross talk, and intermodulation effects.

**General Specifications**

<b>Power Input:</b>	18-30 Volts DC (24 Volts nominal, 125 mA max.) 9-15 Volts DC (12 Volts nominal, 250 mA max.)
<b>LVDT Excitation:</b>	3.0 Vrms (nominal) for primary impedance $\geq 200\Omega$ 1.5 Vrms (nominal) for primary impedance $< 200\Omega$
<b>LVDT Excitation Frequency:</b>	3, 5, or 10 kHz (nominal)
<b>Input Sensitivity Range:</b>	70 mVrms to 5.5 Vrms full scale input produces full scale DC output
<b>Full Scale Outputs:</b>	0 to $\pm 10$ V DC, 5 mA max. 0 to 10 V DC, 5 mA max. 4 to 20 mA sourcing, 500 $\Omega$ maximum loop resistance
<b>Output Non-linearity:</b>	$\leq \pm 0.01\%$ of full scale output
<b>Output Noise / Ripple:</b>	$\leq 5$ mVrms (voltage output) $\leq 10$ $\mu$ Arms (current loop output)
<b>Frequency Response (-3dB):</b>	250 Hz (nominal)
<b>Operating Temperature:</b>	0°F to +160°F (-20°C to +70°C)
<b>Thermal Coefficient of Sensitivity:</b>	0.01% of FSO/°F (nominal) (0.018% of FSO/°C nominal)

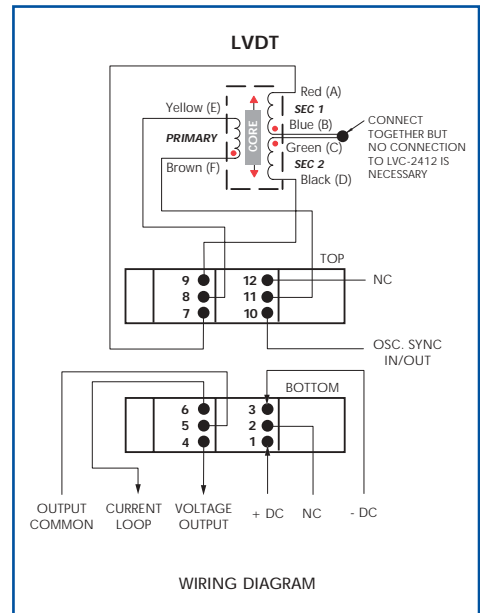
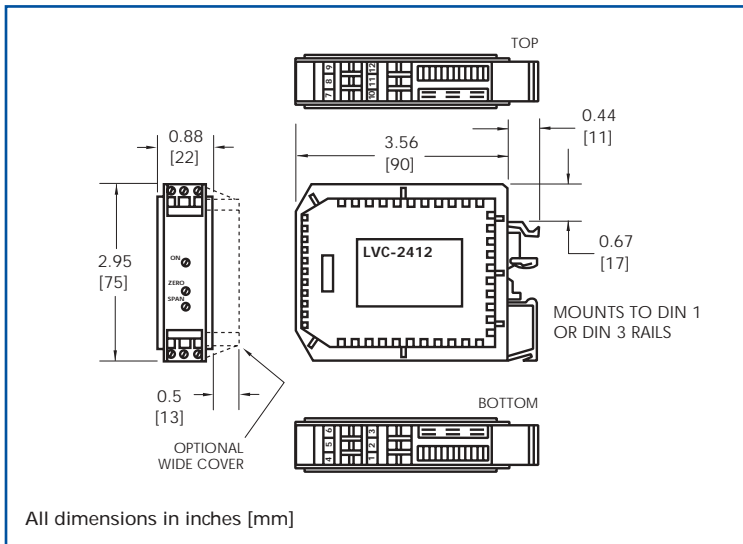

**Ordering Information**

Order model LVC-2412  
For specifications on other Macro Sensors LVDT signal conditioners, please visit our website at [www.macrosensors.com](http://www.macrosensors.com).



*Innovators in Position Sensing*

All specifications subject to change without notice.  
© 2004 Macro Sensors 10/21/04

7300 US Route 130 North, Bldg. 22  
Pennsauken, NJ 08110-1541 USA  
tel: 856-662-8000  
fax: 856-661-8000  
[www.macrosensors.com](http://www.macrosensors.com)  
[lvds@macrosensors.com](mailto:lvds@macrosensors.com)

