

Instruction Manual
Low Voltage
DC-Operated
LVDT
Signal Conditioner
Model LVC-2400

Macro SensorsTM

Division Of
Howard A. Schaevitz
Technologies, Inc.

7300 Industrial Center, Bldg. 22
U.S. Route 130 North
Pennsauken, NJ 08110-1541

Phone: 856-662-8000

FAX: 856-317-1005

DESCRIPTION

The LVC-2400 is a compact single channel DC-operated signal conditioner capable of operating most LVDTs and RVDTs. Operating from isolated 24 to 30 V DC, an LVC-2400 provides all circuitry required to operate an LVDT position sensor and provide a high level, low noise analog DC output suitable for feeding analog or digital indicators, PLCs, and other system indicating and control instrumentation or a 4-20 mA 4-wire current loop output. The LVC-2400 features user-selectable excitation frequency and gain to function with sensors having widely different sensitivities. Connections are made via recessed screw terminals at the top and bottom of the case, which mounts on DIN 1 or DIN 3 rail.

SPECIFICATIONS

Power Input Voltage.....	24 to 30 V DC, 50 mA max.
LVDT Excitation Voltage.....	3 V rms (Nom.)
LVDT Excitation Frequency.....	3 kHz, 5 kHz or 10 kHz
LVDT Primary Impedance.....	200 Ohms (min.)
Output, Voltage Mode.....	± 7.5 V DC @ 5 mA
Output, Current Mode.....	4-20 mA sourcing, 300 Ohms max
Frequency Response.....	-3 db at 250 Hz
Output Ripple.....	<10 mV rms
Output Impedance.....	<10 Ohms
Nonlinearity.....	$\pm 0.01\%$ FSO
Operating Temp. Range.....	0°F to +160°F (-18°C to +70°C)
Temp. Coeff. of Sens.....	0.01% FSO/°F (0.018% FSO/°C)
Controls.....	Zero and Span
Weight.....	3 ounces (100 grams)

MOUNTING

The LVC-2400 is designed to mount on the DIN rail mounting system, including DIN 1, 32mm X 15mm asymmetrical, or DIN 3, 35mm X 7.5mm or 15mm symmetrical, rails as illustrated below.

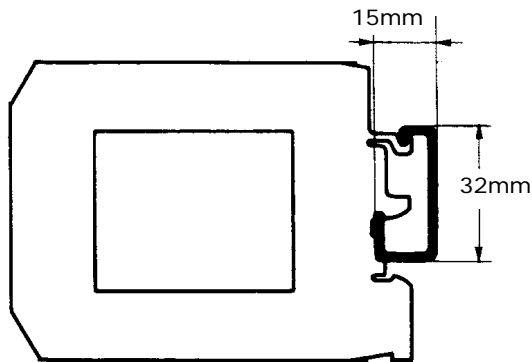

DIN 1 Mounting

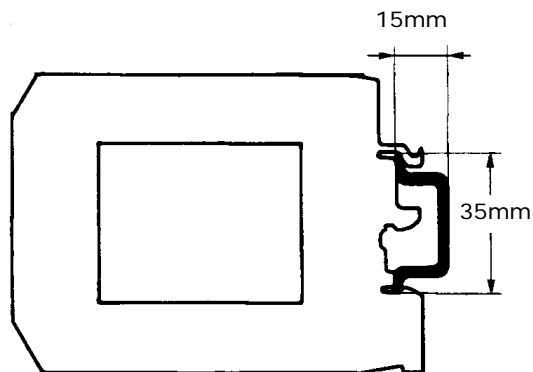

DIN 3 Mounting

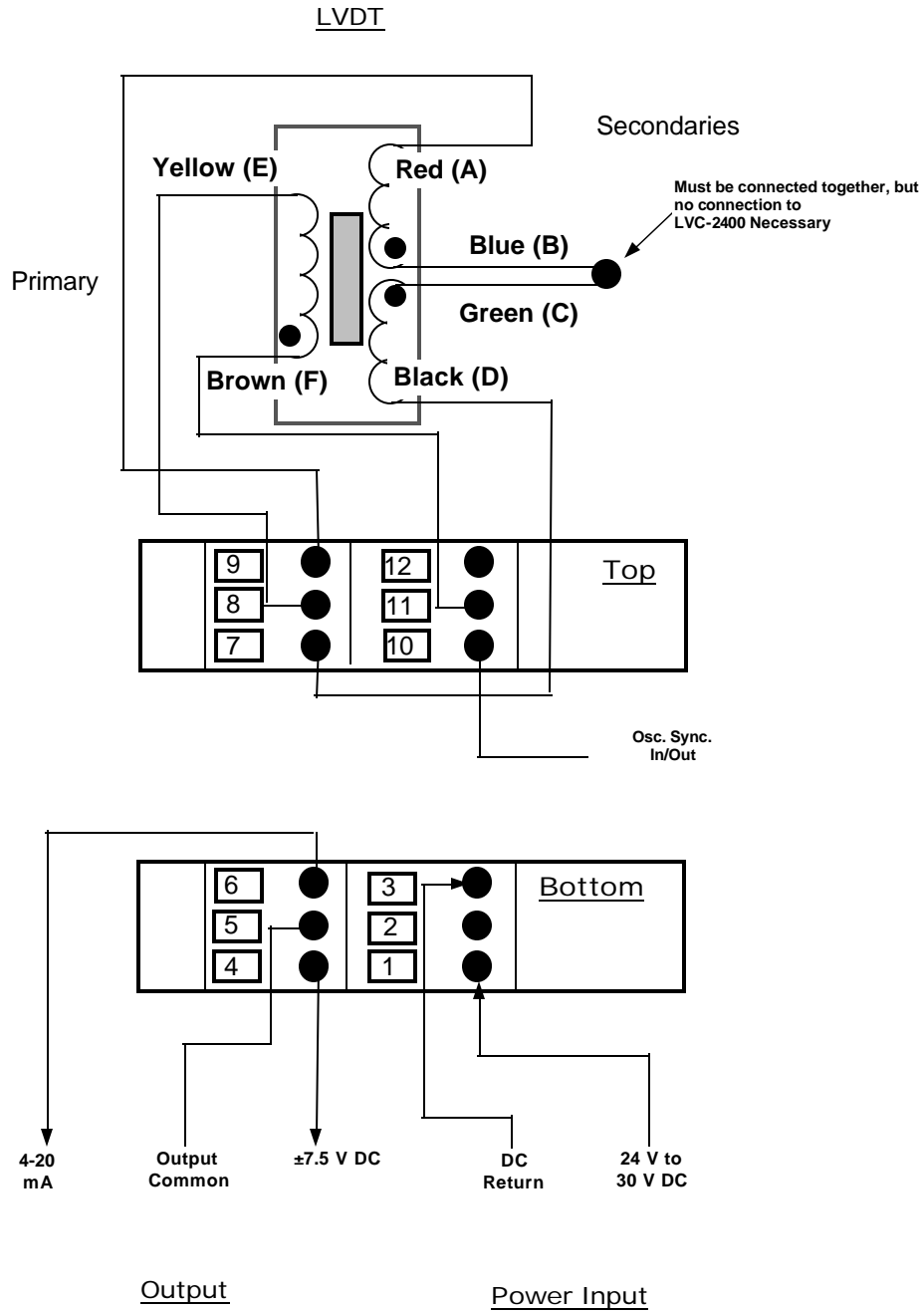

Note: Do not connect output common to power supply return

Wiring Note: The wire colors and/or letters shown in the connection diagram apply only to Macro Sensors' standard AC LVDTs with 6 lead wires or 6-pin connectors. For LVDTs with other terminations such as BB series gaging probes or SQ series heavy duty LVDTs, or for extension cables used with LVDTs, consult the data sheet accompanying the LVDT or cable for the correct color codes or terminal connections. Connect the LVDT's primary and secondaries to the signal conditioner according to the wiring diagram, observing the magnetic polarity dots on the LVDT winding schematic.

CONNECTIONS

All wire connections to the LVC-2400 are through industry standard recessed screw clamp terminals that will accept wire sizes from #28AWG to #12 AWG, either solid or stranded. Wires should be stripped 5/16" (8 mm) which will provide the proper length of conductor without exposing any bare wire. DC power input wiring should utilize a minimum size of #22 AWG.

INTERNAL ACCESS

It may be necessary to gain access to the inside of the LVC-2400 to adjust excitation frequency and/or gain jumpers. **De-energize DC power.** Using a knife blade, small screwdriver or similar tool, gently pry off the cover at points indicated in figure below.

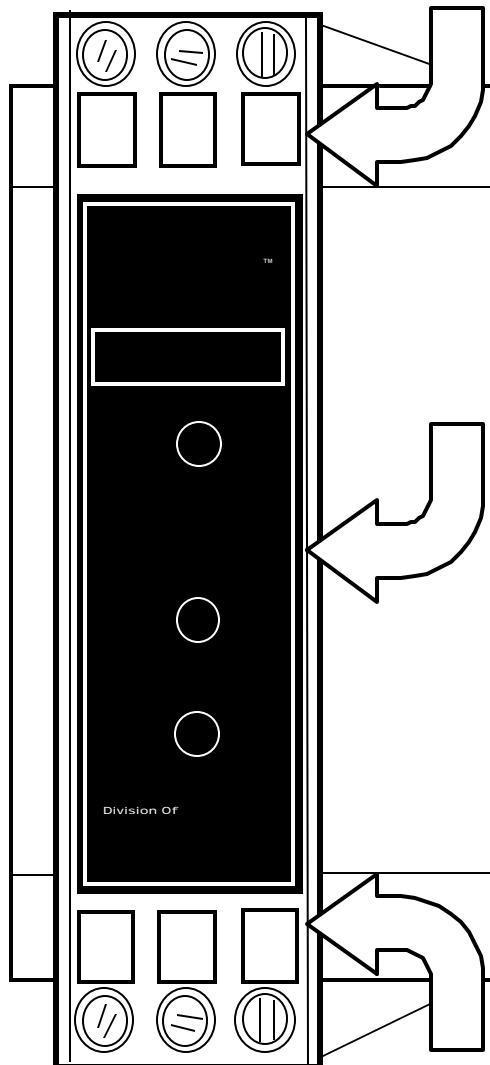
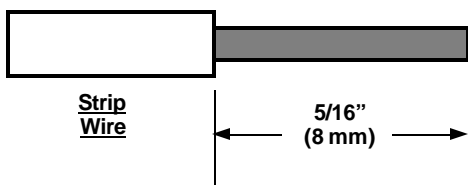

EXCITATION FREQUENCY SELECTION

The LVC-2400 has three user-selectable LVDT excitation frequencies. The desired frequency is normally set to match the specifications and/or recommended operating frequency of the LVDT being used. As shipped from the factory, the unit is set for 3 kHz excitation frequency which is common to many LVDTs. Frequency is changed by jumpers (shorting bars) on S1, S2 and S3. (see Figure 1). As supplied, a jumper is positioned across S1 as shown in Figure 1. To obtain 5 kHz, move the jumper from S1 to S2. To obtain 10 kHz, move the jumper from S1 to S3.

OUTPUT GAIN SELECTION

The LVC-2400 can operate with LVDTs having a wide range of sensitivities. Coarse gain selection is provided to permit operation with most LVDTs. To set coarse gain, the full scale AC output of the LVDT being used must first be determined by performing the following calculation:

Sensitivity in Volts/.001" X Excitation Voltage X Full Stroke in thousandths of an inch = Full Scale Output (V AC rms)

Example 1: ±0.050" Stroke LVDT

Sensitivity: 0.0065 V/.001" X 3 V rms X 50 (1/2 range in .001") = 0.975 V AC rms Full Scale LVDT Output

Example 2: ±1.000" Stroke LVDT

Sensitivity: 0.0065 V/.001" X 3 V rms X 1000 (1/2 range in .001") = 1.95 V AC rms Full Scale LVDT Output

Gain may be adjusted by placing jumpers S4, S5, S6, and S7 (shorting bars) in positions shown in the table below. Placing jumpers as instructed will yield a ± 7.5 V DC output at full scale LVDT displacement.

GAIN SELECTION TABLE				
LVDT Full Scale Output AC Volts	S4	S5	S6	S7
0 - 0.3V	Open	Open	Open	Open
0.31V - 0.6V	Open	Jumper	Open	Open
0.61V - 2.5V	Open	Jumper	Open	Jumper
2.51V - 5.5V	Jumper	Open	Jumper	Open

 Indicates Jumper positions as shipped from factory

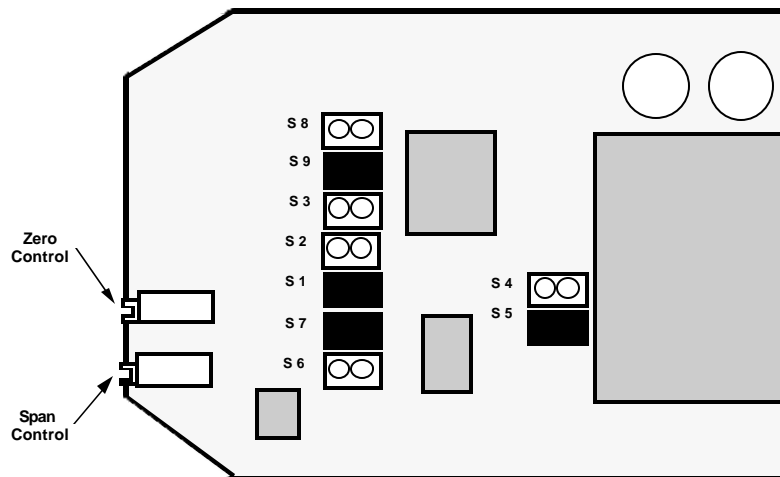
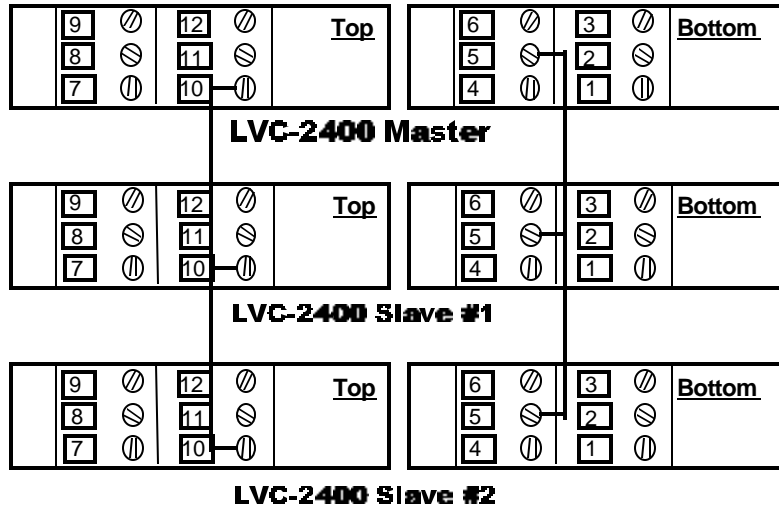

Figure 1

MULTI-CHANNEL APPLICATIONS

A requirement may exist where multiple LVC-2400s are to be used and where units or wiring will be located in close proximity to each other. The LVC-2400 can synchronize the oscillators of multiple units to prevent crosstalk, beating, and intermodulation between units. To synchronize the oscillators, connect together terminal 5 on all units and connect together terminal 10 on all units. These connections are in addition to the connections shown on page 3. One unit should be designated as the "Master" and the balance of the units designated as "Slaves". The "Master" unit's excitation frequency must be set in accordance with the instructions given in the paragraph entitled "Excitation Frequency Selection". On the "Master" unit, move jumper from S8 to S9. "Slave" units must have a jumper (shorting bar) on S8 and all jumpers (shorting bars) must be removed from S1, S2, S3 and S9.



Additional Connections For LVC-2400 Multi-channel
"Master/Slave" Configuration

CALIBRATION PROCEDURE (Voltage Output)

To calibrate, remove LVDT secondary wire, usually Red or (A) from terminal 9. Insert temporary jumper between terminals 7 and 9 (this jumper will be removed after Zero adjustment). Apply DC power to unit and allow a 3-5 minute warm-up. Adjust the Zero control until an output of 0 V DC is obtained between terminals 4 and 5. De-energize unit and remove temporary jumper from between terminals 7 and 9. Re-connect secondary wire Red or (A) to terminal 9. Apply power to unit and move LVDT core or body until an output of 0 V DC is obtained. This position is the true null of the sensor and the reference point from which subsequent position measurements are made.

NOTE: If mechanical adjustment of the core or LVDT body is difficult or impossible, make this adjustment as close as possible and then adjust the Zero control to obtain 0 V DC output. It is important that the LVDT be within 5% of its true null position to ensure that full displacement is within the LVDT's rated linear range. Offsets of more than 5% may result in non-linear results at or near full scale displacement.

Move the LVDT core to its full scale displacement and adjust the Span control to obtain a reading of 7.5 V DC. Outputs of less than 7.5 V DC may be obtained by adjusting the Span control (e.g. 5 V DC). If desired full scale output cannot be obtained by Span control adjustment, reset gain jumpers (shorting bars) to next higher or lower setting as shown in "GAIN SELECTION" table on page 5 and then re-adjust Span control to obtain desired output. If it is necessary to reset gain jumpers.

Unit is now ready for normal operation.

CALIBRATION FOR 100% ZERO OFFSET (Voltage Output)

100% zero offset allows the user to obtain a unipolar output over the full range of the LVDT.

Follow the instructions as described in the "CALIBRATION PROCEDURE" section for full scale use, but adjust the Span control for half the desired full scale output (e.g. 3.75 V DC). Move the LVDT core to "minus" full scale displacement and adjust the Zero control to obtain zero output. Move the LVDT core to "plus" full scale displacement and adjust the Span control for desired full scale output. Repeat this procedure to ensure proper calibration.

Unit is now ready for unipolar operation.

CALIBRATION FOR 4-20mA CURRENT LOOP OUTPUT

To calibrate unit for current output, make sure that current loop connections are made between Terminals 5 and 6. Remove LVDT secondary wire, usually Red (A) from Terminal 9. Insert temporary jumper between terminals 7 and 9 (this jumper will be removed after zero adjustment). Apply AC power to unit and allow a 3-5 minute warm-up. Adjust Zero control until a reading of 12 mA is obtained. De-energize unit and remove jumper from between Terminals 7 and 9. Re-connect secondary wire Red (A) to Terminal 9. Apply power to unit. Move LVDT core or body until 12 mA output is obtained. This position is the true null position of the sensor and the point from which subsequent measurements are made.

NOTE: If mechanical adjustment of the core or LVDT body is difficult or impossible, make this adjustment as close as possible and then adjust the Zero control to obtain 12 mA output. It is important that the LVDT be within 5% of its true null or zero position to insure that full displacement is within the LVDT's rated linear range. Offsets of more than 5% may result in non-linear results at or near the full scale displacement.

Move the LVDT core to its "plus" full scale displacement and adjust the Span control to obtain a reading of 20 mA. Return the core to "minus" full scale position and adjust the Zero control to obtain a reading of 4 mA. Move the core to the "plus" full scale position and adjust the Span control to obtain a 20 mA reading. Repeat above procedure to ensure proper output at both extremes of the core travel.

Unit is now ready for normal current output operation.

Directional Sense

If the slope of the analog output voltage or current is the reverse of the desired slope, i.e., if the output voltage or current increases or decreases opposite to the desired direction of core motion, reverse the LVDT connections to terminals 7 and 9

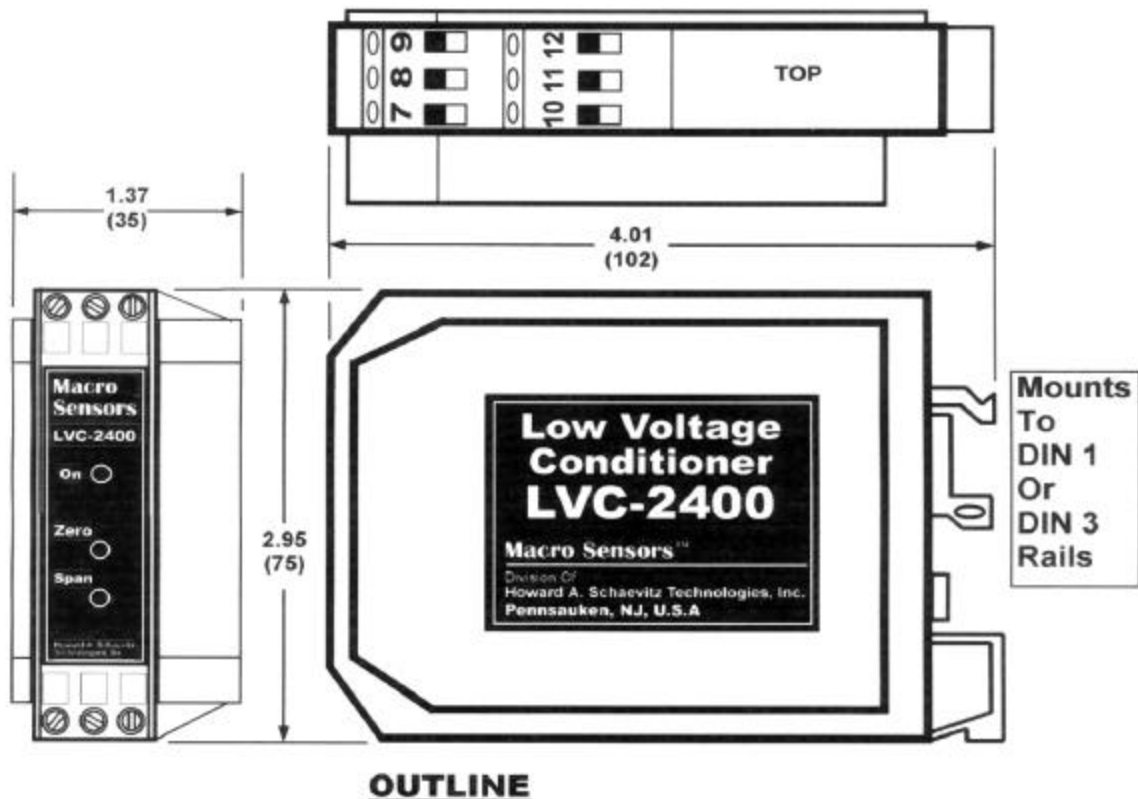

Form #1055 Rev. cw ©Howard A. Schaevitz Technologies, Inc., 2001. Macro Sensors is a registered trade mark of Howard A. Schaevitz Technologies, Inc.